

Technical data sheet - Starscreen 2-hta

Starscreen 2 fractions, hookliftmobile version track mobile

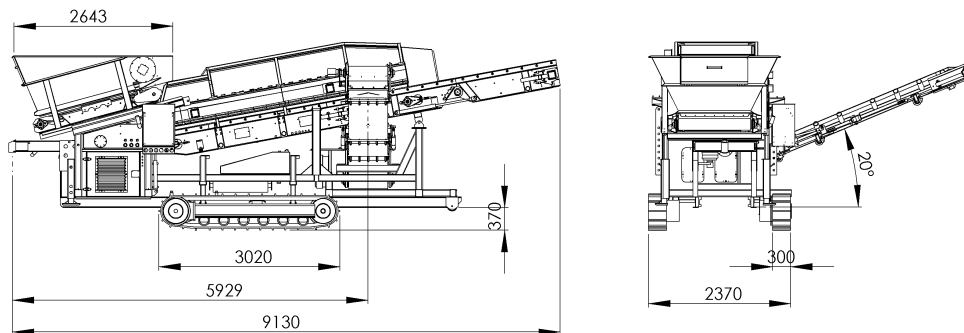

Copyright by ISO 16016!

General

Throughput capacity:	max. up to 120 m ³ per hour
Weight:	approx. 14 t (depends on equipment)
Construction form:	hookliftmobile version track mobile
Acceptances:	CE declaration / vehicle registration according to German road regulation (*)
Transport dimension:	2.55 m x 2.68 m x 6.80 m

Hopper

Material to be conveyed:	All forms of bulk material, compost, earth, rubbish etc.
Capacity volume:	2.50 m ³
Loading height:	2.70 m
Drive:	Spur gears / Danfoss OM
Conveying speed:	Infinitely adjustable, automatic switch on / off in the event of overload.
Belt width:	1.20 m
Profiling:	Profiled belt with smooth surface

Starscreen:

Starscreen fractions:	8 mm – 80 mm depends on customer request
Starscreen dimensions:	1.20 m x 4.20 m
Drive:	Danfoss OMS, high-quality roller chain with hardened, galvanized double sprockets
Bearing:	High quality flange bearings; bearing size depends on screening size. To get a longer life the bearings are provided with dots of central lubrication.
Chain protection:	folding sidewise

Fine conveyor belt

(right hand side)	
Dimensions:	0.65 m x 5.10 m
Conveying speed:	Infinitely adjustable
Profiling:	Smooth
Drive:	Danfoss OM

Over fraction belt (*)

(backward)	
Dimensions:	1.20 m x 2.45 m
Conveying speed:	Infinitely adjustable
Profiling:	Smooth
Drive:	Danfoss OM

Technical data sheet - Starscreen 2-hta

Starscreen 2 fractions, hookliftmobile version track mobile

Conveyor belt (*)

Dimensions:	1.20 m x 3.10 m
Conveying speed:	Infinitely adjustable
Profiling:	Smooth
Drive:	Danfoss OM

Motor specification

Manufacturer:	Perkins / 1104C
Type:	1104
Output:	61 kW
Emission standard:	Certified as latest standard
Cooling:	Water cooled
Diesel tank:	380 litres

Electrical control

Operator switching cabinet:	0.50 m x 0.50 m x 0.21 m
Operation:	Via manual operation (via Poti)
Description:	simple use by automatic start-stop program

Hydraulics

Pumps:	Bosch – Rexroth A10V0 Tandem
Valves:	Danfoss PVG 32
Cooling:	Hydraulic air cooling
Description:	Safety device through level switching off in case of losing hydraulic oil

Tracks:

Dimension:	0.30 m x 3.95 m
	Machine is hydraulic retractable, the track is driven by remote control

Varnish:

Priming:	Eposist varnish
Final varnish:	PU – finish varnish
Colouring:	daffodil yellow (RAL 1007) (**), black (RAL 9005) and galvanized parts

*(optional ordering possibility)

** (optional in other colours available)